

QUALSTAR 2Gb FIBRE CHANNEL OPTIONS

HIGH SPEED DATA TRANSFER
FOR TLS-SERIES SANSmart
AUTOMATED TAPE LIBRARIES



The Fibre Channel Options (FCO) connect TLS-Series SANSmart automated tape libraries to Storage Area Networks (SAN). SAN technology provides high-speed data transfer, unencumbered by LAN user traffic, for backup, data migration and other throughput-intensive applications.

INDUSTRY LEADING PERFORMANCE

The FCOs incorporate the latest technology to provide sustained data transfer rates approaching 200 MB/second per channel and delivering over 16,000 IOPs per channel. Each FCO contains multiple Ultra160 SCSI busses to insure that the tape drives within the library are able to achieve and sustain their maximum aggregate throughput. The dual-channel FCO for eight- and twelve-drive libraries provides two independent Fibre Channel connections for high-availability requirements and fast data transfers.

EASY IMPLEMENTATION

The FCOs use industry standard GBICs and SFPs to deliver sustained performance over distances up to 10 kilometers. The FCO supports Fibre Channel Arbitrated Loop (FC-AL) topology and Fibre Channel Switched Fabric (FC-SW) topologies

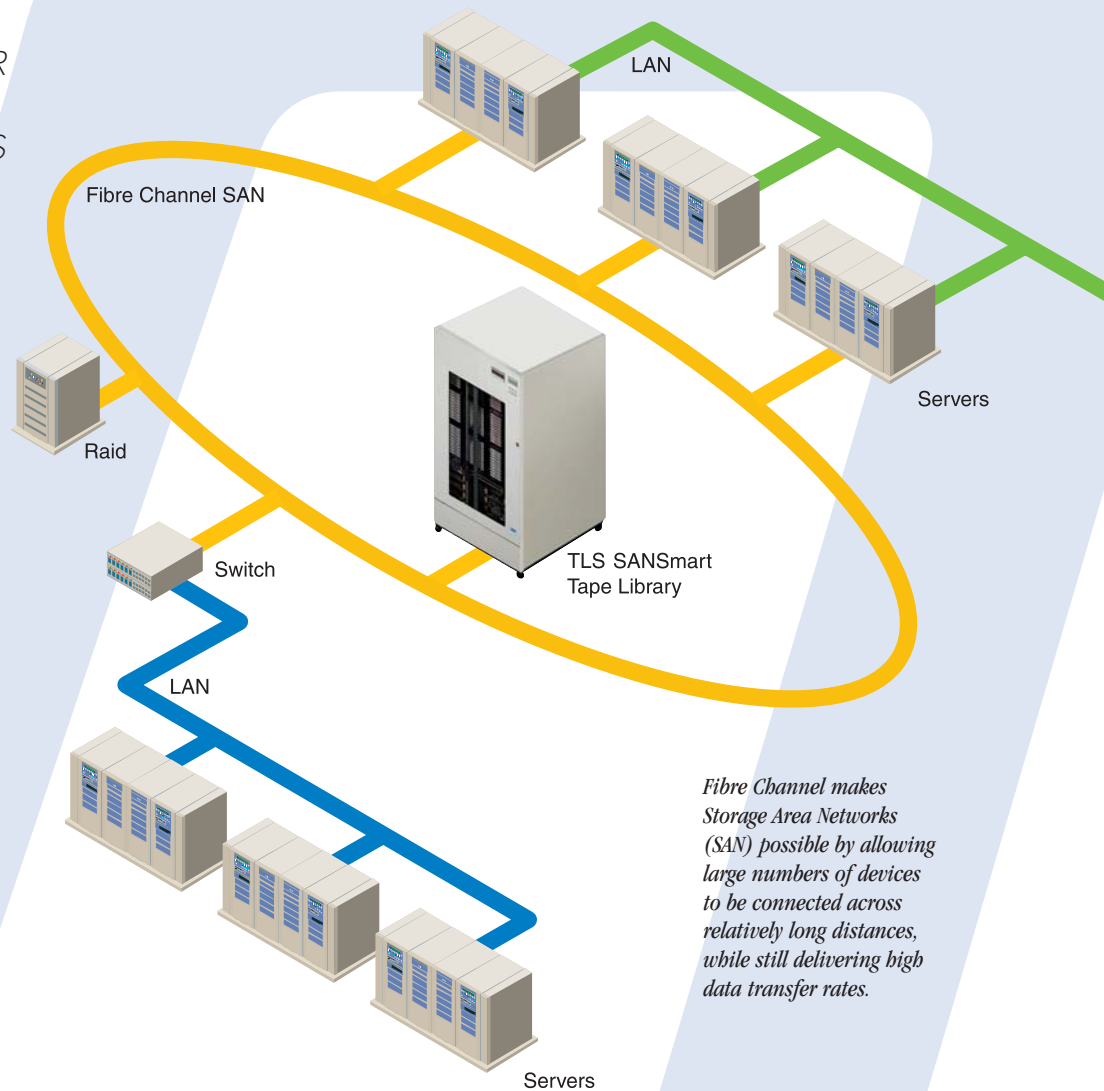

Fibre Channel makes Storage Area Networks (SAN) possible by allowing large numbers of devices to be connected across relatively long distances, while still delivering high data transfer rates.

to integrate into most SAN architectures. Popular host bus adapters, hubs and switches are supported to provide easy connectivity in most installations.

FAST INSTALLATION

Q-Link, the browser-based remote library manager, is built into every FCO, making configuration, monitoring and administration easy. The FCO is also fully integrated with

the TLS menu control system, providing complete configuration and management from the library front panel. No additional installation software is required.

QUALSTAR: SIMPLY RELIABLE

Installation and support are provided by leading VARs and Integrators. Qualstar's *Simply Reliable* Tape Libraries are the preferred choice of IT professionals worldwide.

QUALSTAR 2Gb FIBRE CHANNEL OPTIONS

HIGH SPEED DATA TRANSFER
FOR TLS-SERIES SANs
Smart
AUTOMATED TAPE LIBRARIES



TECHNICAL SPECIFICATIONS

- Single or dual Fibre Channel host ports
- Over 200 MB/second per port
- Over 16,000 IOPs per port
- FC-AL and FC-SW topologies
- 1Gb or 2Gb auto-negotiating
- PLDA compliant
- Class 3 service
- SCSI-FCP protocol
- Uses standard 2Gb GBICs and SFPs

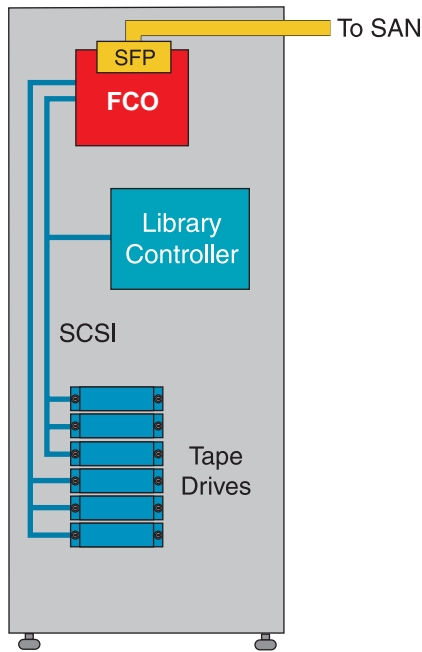

**FIBRE CHANNEL OPTION
FOR 2, 4 AND 6 DRIVE TLS SERIES LIBRARIES**

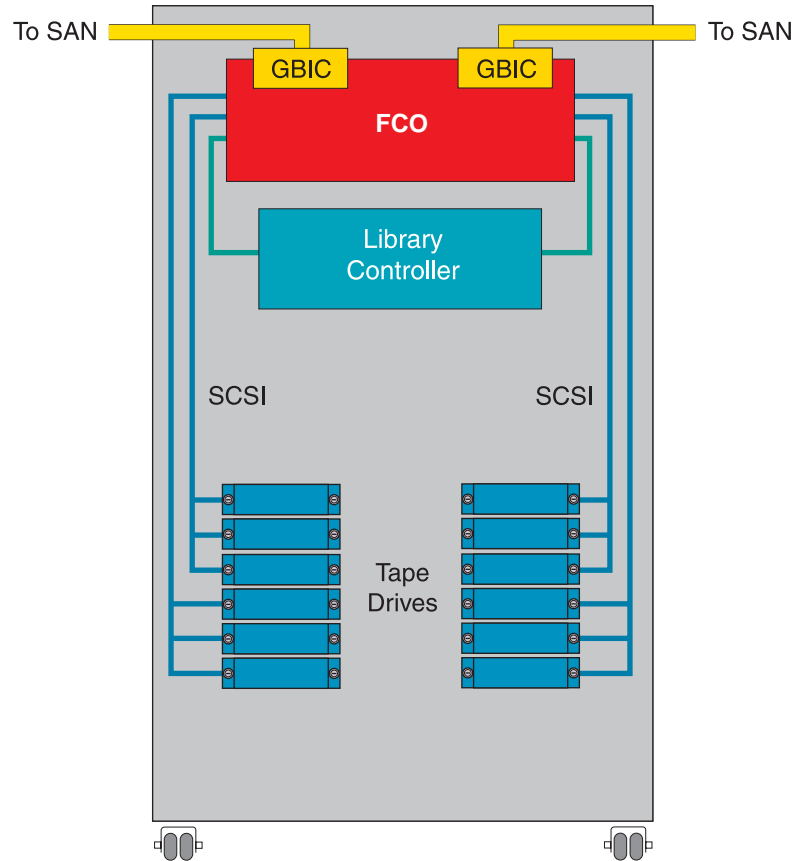

**DUAL-CHANNEL FIBRE CHANNEL OPTION
FOR 8 AND 12 DRIVE TLS SERIES LIBRARIES**

QUALSTAR CORPORATION

3990-B Heritage Oak Court
Simi Valley, CA 93063

NASDAQ: QBAK

Fax: 805-583-7749

Tel: 805-583-7744

800-468-0680

E-mail: sales@qualstar.com

Website: www.qualstar.com

All information and specifications are based on our knowledge of the products at the time of printing. Qualstar reserves the right to change specifications without notice.

Qualstar and the Qualstar logo are registered trademarks of Qualstar Corporation. All other trademarks are the property of their respective owners.

Qualstar products are covered by one or more of the following patents: 6,271,982 and 6,560,061. Other patents pending.

Copyright © 2004 Qualstar Corporation. All rights reserved. Printed in USA. DS 264 5/04